

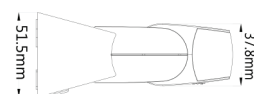

INFRARED MOTION SURFACE MOUNTED SENSORS - SENS001 & SENS002

Specification

Part No.	SENS001, SENS002
Mounting Type	Surface Mounted
Input voltage	220-240V AC 50/60Hz
Detection Range	180°
Detection Distance	12m Max (<24°C)
Detection Motion Speed	0.6-1.5m/s
Rated Load	1200W HAL/ 300W CFL/ 300W LED
Time Delay	Min.10sec±3sec Max.15min±2min (Restarts from last movement)
Ambient Light	<3-2000lux (adjustable)
Ambient Temp	-20 to +40°C
Working Humidity	<93%RH
Power Consumption	approx 0.5W
Installation Height	1.8-2.5m
Housing Material	PC
IP Rating	IP65
Warranty	5 year replacement warranty

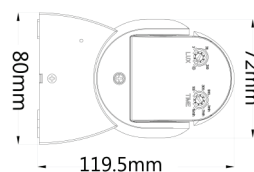

- UV resistant
- 3 wire
- Day/Night recognition
- Manual override

(1) To operate as a light only (i.e. override sensor), turn power off for 3 seconds and then back on

(2) To reverse the override function (i.e. re-introduce the use of the sensor), turn power off for 10 seconds and then back on

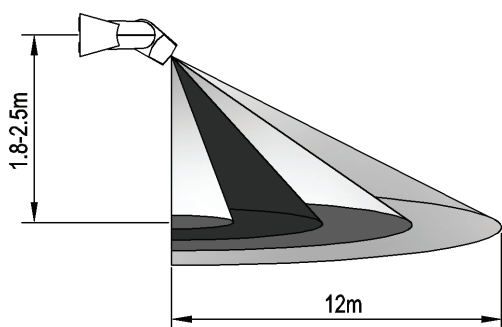

Height of installation: 1.8-2.5m

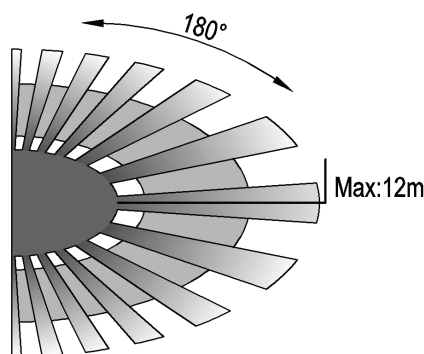

Detection Distance: Max.12m

